

iGX390

Horizontal shaft gasoline (petrol) engine



Moteur à essence à arbre de prise de force horizontal

Benzinmotor mit horizontaler Kurbelwelle

Motore a benzina ad albero orizzontale

Bensinmotor med horisontell axel

Benzinmotor met horizontale uitgaande as

iGX390

The Engine with Built-in Intelligence
iGX™

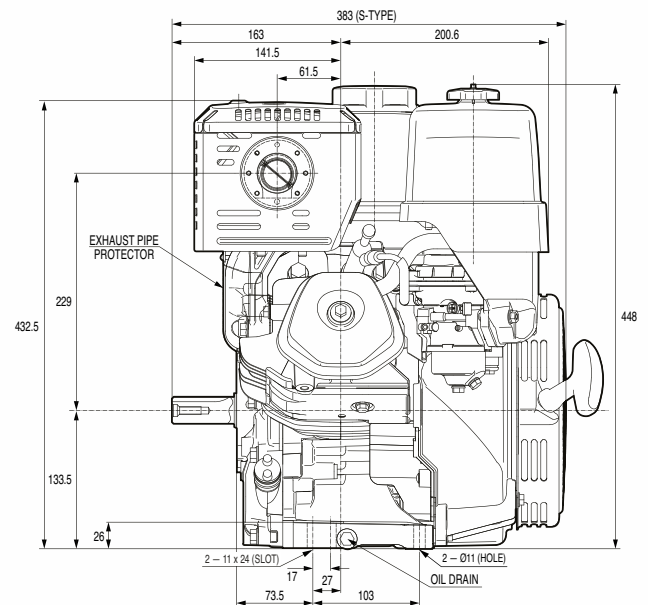
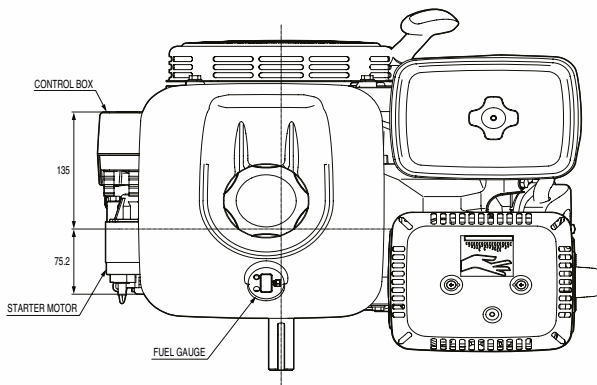
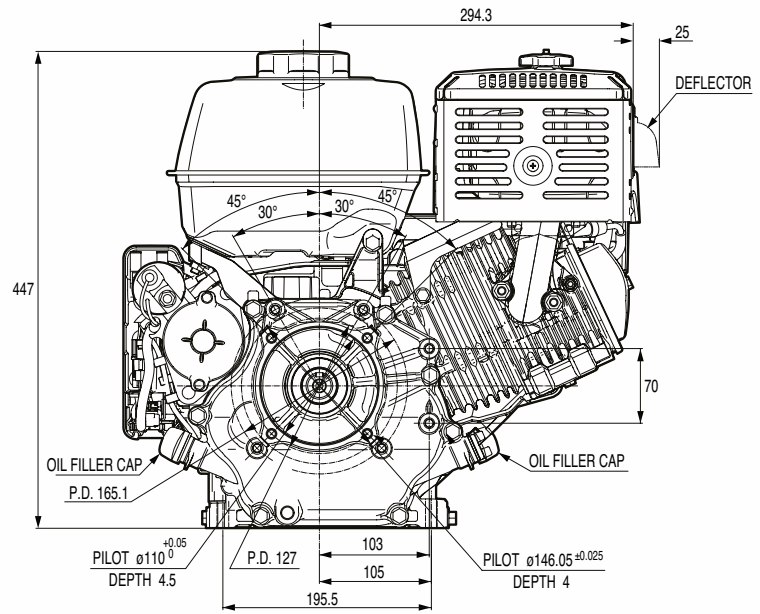
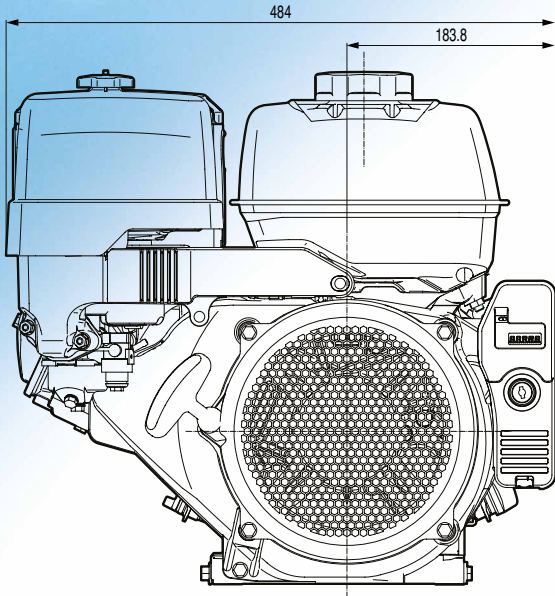

PTO SHAFT DIMENSIONS

Q-TYPE

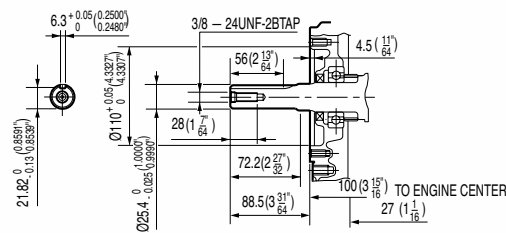

V-TYPE

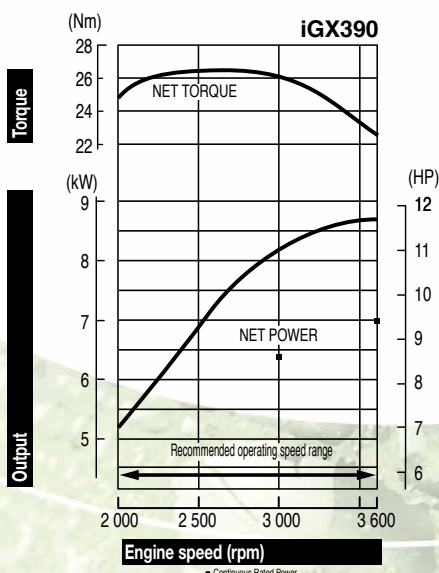
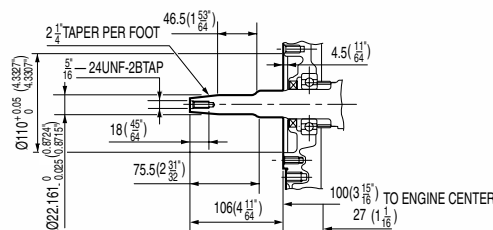

The power rating of the engine indicated in this document is the net power tested on a production engine for the engine model and measured in accordance with SAE J1349 at a specified rpm. Mass production engines may vary from this value. Actual power output for the engine installed in the final machine will vary depending on numerous factors, including the operating speed of the engine in application, environmental conditions, maintenance, and other variables.

La puissance du moteur indiquée dans ce document est une puissance nette obtenue par l'essai d'un moteur de série selon la norme SAE J 1349 à une vitesse de rotation donnée. La puissance d'un autre moteur de production peut être différente de cette valeur indiquée. La puissance réelle d'un moteur installé sur une machine dépendra de différents facteurs comme la vitesse de rotation, les conditions de température, d'humidité, de pression atmosphérique, de maintenance et autres.

Die Leistungsangabe der in diesem Dokument aufgeführten Motoren ist die Netto-Leistung gemäß SAE J1349, getestet bei einer definierten Drehzahl an einem Produktionsmotor. Bei Motoren aus Serienproduktion kann der Wert abweichen. Die Leistungsabgabe in einem Fertigergerät weicht, bedingt durch unterschiedliche Faktoren, wie Motordrehzahl in der Applikation, Umwelteinflüsse, Grad der Instandhaltung und andere Einflüsse ab.

La potenza indicata in questo documento, è la potenza netta rilevata su questo modello di motore in fase di produzione, ed è stata misurata secondo la procedura SAE J1349 ad un numero di giri specifico. Nella produzione di massa si possono riscontrare variazioni rispetto a questi valori. La potenza del motore installato nella macchina può dipendere da numerosi fattori, incluso il numero di giri al quale il motore è impiegato, le condizioni ambientali, dal livello di manutenzione ed altre variabili.

De bepaling van het vermogen van de motor, vermeld in dit document, is het netto vermogen getest op een productiemotor en gemeten in overeenstemming met SAE J1349 aan een specifieke t/min. Motoren van massaproductie kunnen van deze waarde variëren. Het werkelijke vermogen van de geïnstalleerde motor in het eindproduct kan afwijken, afhankelijk van talrijke factoren, zoals de operationele snelheid van de motor in een applicatie, omgevingsfactoren, onderhoud en andere variabelen.

Den i detta dokument nämnda motors effekt, är uppmätt i netto effekt. I enlighet med mätmetoden SAE J1349. Massproducerade motorer kan avvika från nämnda värde. Den faktiska effekten för varje motor kan variera beroende på bl a. varvtal, yttre omgivningar, underhåll, typ av applikation, mm.

Specifications

Model	iGX390
Engine type	Air cooled 4-stroke OHV petrol engine, 25° inclined cylinder, horizontal shaft, cast iron sleeve
Bore x stroke	88 x 64 mm
Displacement	389 cm ³
Compression ratio	8.2 : 1
Net power	8.7 kW (11.7 HP) / 3 600 rpm
Cont. rated power	6.4 kW (8.6 HP) / 3 000 rpm 7.0 kW (9.4 HP) / 3 600 rpm
Max. net torque	26.5 Nm / 2.7 kgfm / 2 500 rpm
Ignition system	Digital CDI with variable ignition timing
Governor system	Electronic (STR.GOVERNOR)
Starting system	Recoil starter, Electric starter
Choke	Automatic
Fuel tank capacity	6.1 l
Fuel cons. at cont. rated power	3.5 L/hr - 3 600 rpm
Engine oil capacity	1.1 l
Dimensions (L x W x H)	409 x 484 x 448 mm
Dry weight	37,0 kg

Spezifikationen

Modell	iGX390
Motortyp	Luftgekühlter 1-Zylinder 4-Takt OHV Benzinmotor, um 25° geneigter Zylinder, horizontale Kurbelwelle, Gußeisen Buchse
Bohrung x Hub	88 x 64 mm
Hubraum	389 cm ³
Verdichtung	8.2 : 1
Netto-Leistung	8.7 kW (11.7 HP) / 3 600 min ⁻¹
Max. Dauerleistung	6.4 kW (8.6 HP) / 3 000 min ⁻¹ 7.0 kW (9.4 HP) / 3 600 min ⁻¹
Max. Netto-Drehmoment	26.5 Nm / 2.7 kgfm / 2 500 min ⁻¹
Zündsystem	Digitale CDI-Zündung mit variablem Zündzeitpunkt
Drehzahlreglersystem	Elektronischer (STR.GOVERNOR)
Starter	Zugstarter, Startermotor
Choke	Automatisch
Tankinhalt	6.1 Liter
Benzinverbrauch bei Dauerleistung	3.5 L/h - 3 600 min ⁻¹
Motorölkapazität	1.1 Liter
Maße (L x B x H)	409 x 484 x 448 mm
Trockengewicht	37,0 kg

Specificaties

Model	iGX390
Motortype	Luchtgekoelde 4-takt OHV benzinmotor, 25° hellende cilinder, horizontale uitgaande as, gietijzere cilinderbus
Boring x slag	88 x 64 mm
Cilinderinhoud	389 cm ³
Compressie	8.2 : 1
Netto vermogen	8.7 kW (11.7 HP) / 3 600 t/min
Continu nominaal vermogen	6.4 kW (8.6 HP) / 3 000 t/min 7.0 kW (9.4 HP) / 3 600 t/min
Max. netto koppel	26.5 Nm / 2.7 kgfm / 2 500 t/min
Ontsteking	Digitale CDI met variabel ontstekingstijdstip
Regelinrichting	Electronisch (STR.GOVERNOR)
Startsysteem	Repeteerstarter, Startmotor
Choke	Automatisch
Tankinhoud	6.1 Liter
Brandstofverbruik aan cont. nominaal vermogen	3.5 l/u - 3 600 t/min
Motoroliecapaciteit	1.1 Liter
Afmetingen (L x B x H)	409 x 484 x 448 mm
Drooggewicht	37,0 kg

Spécifications techniques

Modèle	iGX390
Type du moteur	Moteur à essence monocylindre 4 temps OHV, refroidissement à air, cyl. incliné 25°, arbre de prise de force horizontal, cyl. chemisé en fonte
Alésage x course	88 x 64 mm
Cylindrée	389 cm ³
Taux de compression	8.2 : 1
Puissance nette	8.7 kW (11.7 HP) / 3 600 tr/mn
Puissance en service continu	6.4 kW (8.6 HP) / 3 000 tr/mn 7.0 kW (9.4 HP) / 3 600 tr/mn
Couple maximum	26.5 Nm / 2.7 kgfm / 2 500 tr/mn
Système d'allumage	CDI allumage numérique avec avance variable
Système de régulateur	Electronique (STR.GOVERNOR)
Système de démarrage	Lanceur à rappel, Démarreur
Volet de départ à froid	Automatique
Cap. du réservoir d'ess.	6.1 l
Consommation de carburant en service continu	3.5 litre(s)/heure - 3 600 tr/mn
Capacité d'huile moteur	1.1 l
Dimensions (L x l x H)	409 x 484 x 448 mm
Poids à sec	37,0 kg

Dati tecnici

Tipo	iGX390
Tipo di motore	Motore monocilindrico OHV ad albero orizzontale, ciclo otto, 4 tempi, cilindro inclinato di 25° raffreddamento ad aria forzata, cilindri in ghisa
Alesaggio x corsa	88 x 64 mm
Cilindrata	389 cm ³
Rapporto di compressione	8.2 : 1
Potenza netta	8.7 kW (11.7 HP) / 3 600 giri/min
Potenza nominale continua	6.4 kW (8.6 HP) / 3 000 giri/min 7.0 kW (9.4 HP) / 3 600 giri/min
Coppia massima	26.5 Nm / 2.7 kgfm / 2 500 giri/min
Accensione	Digital CDI con anticipo accensione variabile
Regolatore di giri	Electronico (STR.GOVERNOR)
Avviamento	Autovolgente, Elettrico
Starter (Choke)	Automatico
Capacità serbatoio	6.1 Litri
Consumo di combustibile alla potenza continuativa	3.5 Litri/ora - 3 600 giri/min
Capacità coppa olio	1.1 Litri
Dimensioni (Lu x La x A)	409 x 484 x 448 mm
Peso a secco	37,0 kg

Specificationer

Modell	iGX390
Motortyp	Luftkyld 4-takts bensinmotor med överliggande ventiler, 25° lutande cylinder, Horisontal axel, cylinderfoder i gjutjärn
Cylinderdiameter x slaglängd	88 x 64 mm
Slagvolym	389 cm ³
Kompressionsförhållande	8.2 : 1
Netto effekt	8.7 kW (11.7 HP) / 3 600 varv per minut
Rek. kontinuerlig effekt	6.4 kW (8.6 HP) / 3 000 varv per minut 7.0 kW (9.4 HP) / 3 600 varv per minut
Max. netto vridmoment	26.5 Nm / 2.7 kgfm / 2 500 varv per minut
Tändsystem	Digital CDI med variabel tändning
Varvtalsregulator	Elektronisk (STR.GOVERNOR)
Startsystem	Startapparat, Startmotor
Choke	Automatisk
Tankvolym	6.1 Liter
Bränsleförbrukning vid kontinuerlig märkeffekt	3.5 L/tim - 3 600 varv per minut
Oljevolym	1.1 Liter
Dimensioner (L x B x H)	409 x 484 x 448 mm
Tornvikt	37,0 kg

All specifications are subject to change without notice. Les caractéristiques techniques peuvent être modifiées à tout moment et sans préavis. Spécificationerna kan ändras utan föregående meddelande.

Le specifiche sono soggette a cambiamento senza preavviso. Die Spezifikationen können ohne Vorankündigung geändert werden. Alle technische specificaties kunnen op elk ogenblik en zonder kennisgeving gewijzigd worden.

HMEL - TS iGX390 - 8808 Jan. 2020 - Printed in Belgium

honda.com

HONDA

Honda Motor Europe Logistics NV

Langerbruggestraat 104
B-9000 Gent
TEL: + 32 (0)9 250 12 11

www.honda-engines-eu.com

Honda Engines - France

Honda Motor Europe Ltd Succursale France • Parc d'Activités de Pariest • Allée du 1^{er} Mai, BP 46 • Croissy Beaubourg F-77312 Marne-la-Vallée Cedex 2 • TEL: + 33 (0)1 60 37 32 45

Honda Engines - Germany

Honda Deutschland Ndl. der HME Ltd. • Hanauer Landstraße 222-224 • D-60314 Frankfurt
TEL: + 49 69 8309-365

Honda Engines - Italy

Honda Motor Europe Logistics NV • Via Maestri del Lavoro 1 • I - 37068 Vigasio (VR)
TEL: + 39 045 6173341

Honda Engines - Sweden

Honda Motor Europe Ltd Filial Sverige • Box 31002 • SE-200 49 Malmö
TEL: + 46 40 38 07 18

Honda Engines - United Kingdom

Honda Motor Europe Logistics NV • Viscount Way, South Marston Park • Swindon SN3 4TN, UK
TEL: + 44 (0) 1455 559429

Honda Engines - Russia

Representative office of Honda Motor Europe Logistics in Russia
Building 1, Pridorozhnaya Street, Sharapovo settlement, Marushkinsky District • 108809 Moscow, Russian Federation
TEL: + 7 (495) 2288123